

# Canine House of Cards



Build a two-story building for Ruff out of index cards, using just one shape—a square, an arch, or a triangle. Then see if it can support the weight of a jumbo dog biscuit on top!

## 1 Get what You need.

- Index cards • Tape • Large dog biscuits

## 2 Test the shapes and Pick one to build with.

Tape together a square, arch, and triangle out of index cards, and test each one for strength and stability. Push down on them and rock them side to side. Choose one shape to build with—the one you think will make the strongest, most stable structure. Be sure to follow the building rules below.

### Building Rules:

1. Build with one shape only.
2. Your building must be at least two stories high.
3. You cannot lay a shape on its side.
4. You can tape shapes together.
5. You can build a flat platform on top for the dog biscuit.

## 3 Brainstorm some ideas

about the best way to build your two-story building. How wide should you make the base? What kind of surface or platform will be needed to support the dog biscuit?

## 4 Build a two-story building.

Use tape and index cards to construct a building out of the shape you chose.

## 5 Test Your design.

Can you place a dog biscuit on top without it falling off or the building toppling over? Can your building support even more dog biscuits? If not, redesign. You can even start over using a different shape.

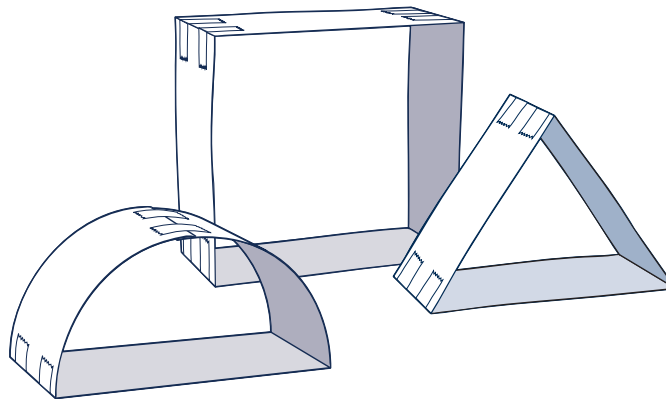

To make the arch, overlap the two index cards about an inch at the top, then tape.

### Chew on This!

The material that a building is made from—wood, concrete, brick, or steel, for example—affects how strong and stable it is. But the shapes used to build a structure also help the structure support weight. In this activity, you tested three commonly used architectural shapes: arches, squares, and triangles. The material you used was weak (thin index cards), so you had to rely on the shape to help provide strength. And, now that you've tried this out, you know which shape is the strongest of them all!

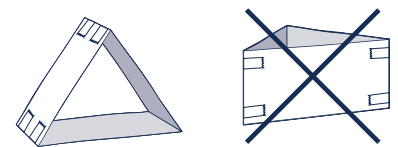

Shapes must be upright (see triangle at left), not on their side (at right).

# Cool science Jobs!

Like designing buildings?  
Then you might love  
one of these jobs.

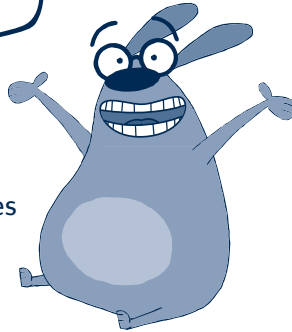

## Architectural Engineer

An architect decides on the form and appearance of a building, but it's the architectural engineer who makes sure everything inside it works. A skyscraper might need fast elevators, a concert hall might require soundproofing, and a "green" school might light its rooms with solar energy. An architectural engineer has the expertise to make it all happen!

## Engineering Geologist

The leaning tower of Pisa leans because it was built on unstable ground. If only the town of Pisa had hired an engineering geologist! Before a building is built, engineering geologists study the rocks and soil beneath it, making sure it has a stable foundation. They also evaluate whether buildings, bridges, and roads face dangers like landslides, earthquakes, and flooding.



Watch the related FETCH! episode, "When Home is a House of Cards," on PBS KIDS GO! (check local listings) or visit the FETCH! Web site at [pbskidsgo.org/fetch](http://pbskidsgo.org/fetch).



FETCH! is produced by WGBH Boston. Major funding for FETCH! is provided by the National Science Foundation and public television viewers. Corporate funding is provided by Greendog®. This FETCH! material is based upon work supported by the National Science Foundation under Grant No. 0714741. Any opinions, findings, and conclusions or recommendations expressed in this material are those of the author(s) and do not necessarily reflect the views of the National Science Foundation. © 2008 WGBH Educational Foundation. All rights reserved. FETCH!, the characters and related indicia are trademarks of the WGBH Educational Foundation. All third party trademarks are the property of their respective owners. Used with permission.

Fold

# Fetch!

# Canine House of Cards

Sure, I may be a dog with a TV show, but I've got even bigger dreams, like owning my own media empire—radio, TV, magazines, movies, and more! I can picture it now . . . goodbye Studio G, hello RUFF WORLDWIDE MEDIA COMPLEX! Build me a model of my new headquarters—and make sure there's a dog bone statue on top. I want everyone to know a dog runs the show!

## GOOO FETCH!

